

Scientech AB80 RLC Series and Parallel Resonance is a compact, ready to use experiment board for RLC Series and Parallel Resonance. This board is useful for students to study and understand operation of the resonance condition in RLC networks.

Scientech Analog Electronics Experiment Boards are designed as a comprehensive Modular solution for beginners to explore the fundamentals of a variety of basic building blocks in Analog Electronics. The boards are very user friendly and support self learning through flexibility of making circuit connections. Schematic diagrams on the boards provide easy understating of the concepts. Test points are provided to observe the waveforms/ signals and to measure voltages at different nodes. The boards can be used as standalone unit with Function Generator, or can be used with Scientech Analog Labs; Scientech 2612/ Scientech 2612A / Scientech 2613. These labs have built in DC Power Supply, AC Power Supply, Function Generator, Modulation Generator, Continuity Tester, Toggle Switches, and Potentiometers. Product Tutorial with theory, description, explanation, procedure, references and results is available online on www.ScientechLearning.com .

Features

- On board test points to observe signals
- On board schematic diagram
- Flexibility of making circuit connections
- Light weight & compact
- Online Product Tutorial

Scope of Learning

- Study of resonance in series RLC circuit
- Study of resonance in parallel RLC circuit
- High cutoff frequency of Low pass filter
- Pass band gain of Low Pass Filter
- Plot the frequency response of Low Pass Filter

Optional

- Simtel Analog Electronics Software

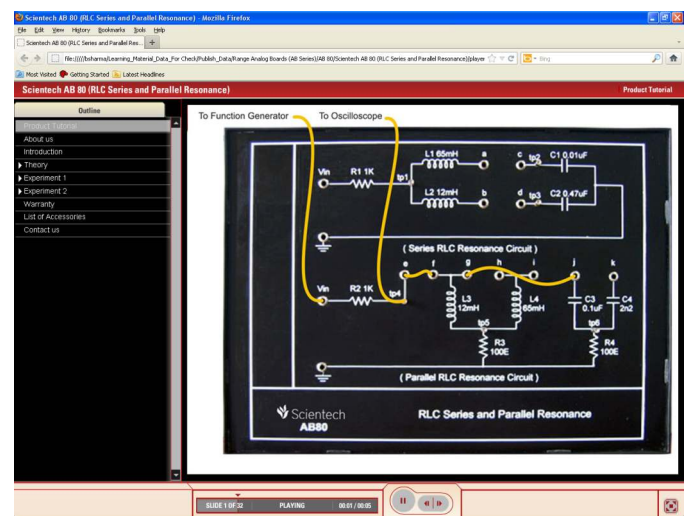

Online Product Tutorial